

# German Head

Made in Brazil



Inspired by the Original German Design,  
manufactured by Brazilian  
OEM Supplier.



**AutoLinea**  
— performance —

# Who We Are

## AutoLinea

Autolinea, the aftermarket division of Hübner Group, combines the industrial structure and the OEM quality know-how with competitiveness and strong network of distributors in Brazil and abroad, exporting to 30 countries across five continents, assuring a positive and global presence over the last 32 years.



AutoLinea

## Hübner Group

Hübner Group started its operation in 1980 and is one of the major suppliers for automotive industry in Brazil, co-operating with OEM, Tier 1 and Tier 2 customers. Besides Autolinea, the Group has other 04 industrial sites dedicated for foundry and machining of iron, steel and aluminum products. The constant development of projects, production line improvement, high standards application and integration among Hübner Group units strengthen its position within the segments in which operates.



Iron Foundry



Steel/Iron Foundry



Machining Shop



Alumnium Foundry

# Air Cooled Engine Case

Connecting Rods parameters options, according partnumbers and required performances.



**AutoLinea**  
— performance —



# Technical Information:

## Air Cooled Engine Case:

AutoLinea part Number	Seat Bore kit (mm)	Piston (mm)	Clearancing Crankshaft (mm)	Rear Reinforcement	Inner diameter (mm)	Guide bushing	Dryseal (plug)	Send seal	Oil holes		Valve hole by pass
									Pump	Cooler	
0201-850100	ø90	ø85,5 ø87 ø88	no 69	no	ø12	2	3/8"	no	ø12 + ø12	ø11x14 - ø8X14	1
0202-850100	ø90	ø85,5 ø87 ø88	no 69	no	ø16	2	3/8"	no	ø15,5 + ø12	ø11x16 - ø10X16	2
0203-900100	ø96	ø90,5 ø92	yes 88	yes	ø16	6	3/8"	no	ø15,5 + ø12	ø11x16 - ø10X16	2
0204-900200	ø96	ø90,5 ø92	yes 88	yes	ø16	6	3/8"	yes	ø15,5 + ø12	ø11x16 - ø10X16	2
0205-940100	ø97,3	ø94	yes 88	yes	ø16	6	3/8"	no	ø15,5 + ø12	ø11x16 - ø10X16	2
0205-940200	ø97,3	ø94	yes 88	yes	ø16	6	3/8"	yes	ø15,5 + ø12	ø11x16 - ø10X16	2

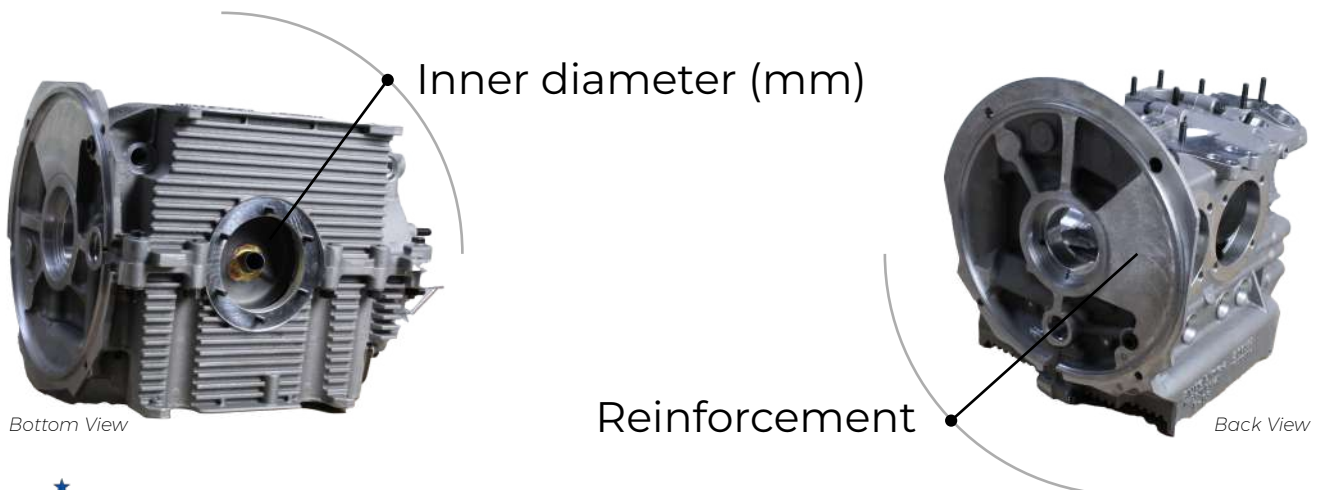
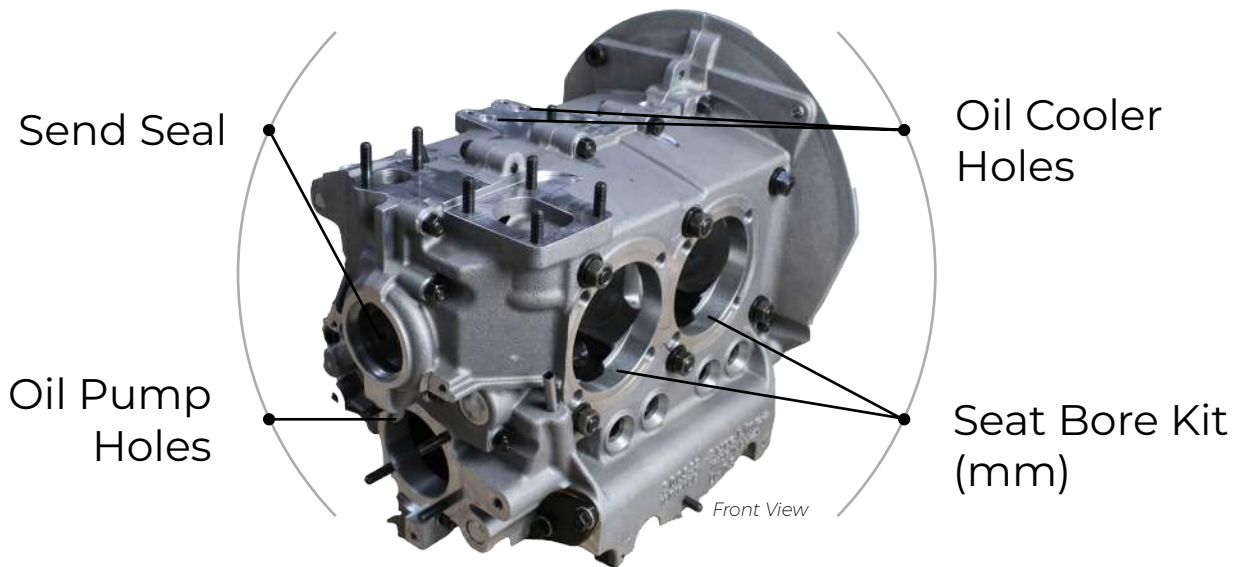

# Air Cooled Cylinder Head

Connecting Rods parameters options, according partnumbers and required performances.



**AutoLinea**  
— performance —

# Technical Information:

## Air Cooled Cylinder Head:

AutoLinea Part Number	Seat bore kit (mm)	Piston (mm)	Depth Seat bore kit (mm)	Chamber Volume (Cm3)	Total Height (mm)	Diameter of the intake valves (mm)	Diameter of exhaust valves (mm)	Spark Plug Holes (mm)	Bolt Holes (mm)	Guide boss
0101-853532	ø94	ø85,5 ø87 ø88	13,45	50	128	*	*	12 (3/4in)	ø11	yes
0102-853532	ø94	ø85,5 ø87 ø88	13,45	50	128	ø35,5	ø32	14 (1/2in)	ø11	yes
0103-854032	ø94	ø85,5 ø87 ø88	13,45	50	128	ø40,0	ø32	12 (3/4in)	ø11	yes
0104-904032	ø98,4	ø90,5 ø92	13,45	50	128	ø40,0	ø32	112 (3/4in)	ø11	yes
0105-904035	ø98,4	ø90,5 ø92	13,45	50	128	ø40,0	ø35,5	12 (3/4in)	ø11	yes
0106-853532	ø94	ø85,5 ø87 ø88	13,45	50	128	*	*	12 (3/4in)	ø11	no
0107-853532	ø94	ø85,5 ø87 ø88	13,45	50	128	ø35,5	ø32	14 (1/2in)	ø11	no
0108-854032	ø94	ø85,5 ø87 ø88	13,45	50	128	ø40,0	ø32	12 (3/4in)	ø11	no
0109-904032	ø98,4	ø90,5 ø92	13,45	50	128	ø40,0	ø32	12 (3/4in)	ø11	no
0110-904035	ø98,4	ø90,5 ø92	13,45	50	128	ø40,0	ø35,5	12 (3/4in)	ø11	no
0111-944035	ø101,2	ø94	13,45	50	128	ø40,0	ø35,5	12 (3/4in)	ø11	no
0112-854035	ø94	ø85,5 ø87 ø88	13,45	50	128	ø40,0	ø35,5	12 (3/4in)	ø11	no
16-00029	ø94	ø85,5 ø87 ø88	4,9	38	116,7	ø35,5	ø30	14 (1/2in)	ø9	yes

\* Not supplied with valve seats and valve guides.



# Technical Information:

## Air Cooled Cylinder Head *assembled with valves:*

Part Number AutoLinea	Seat bore kit (mm)	Piston (mm)	Depth Seat bore kit (mm)	Chamber Volume (Cm <sup>3</sup> )	Total Height (mm)	Diameter of the intake valves (mm)	Diameter of exhaust valves (mm)	Spark Plug Holes (mm)	Bolt Holes (mm)	Guide boss
0102-853532A	ø94	ø85,5 ø87 ø88	13,45	50	128	ø35,5	ø32	14 (1/2in)	ø11	yes
0107-853532A	ø94	ø85,5 ø87 ø88	13,45	50	128	ø35,5	ø32	14 (1/2in)	ø11	no

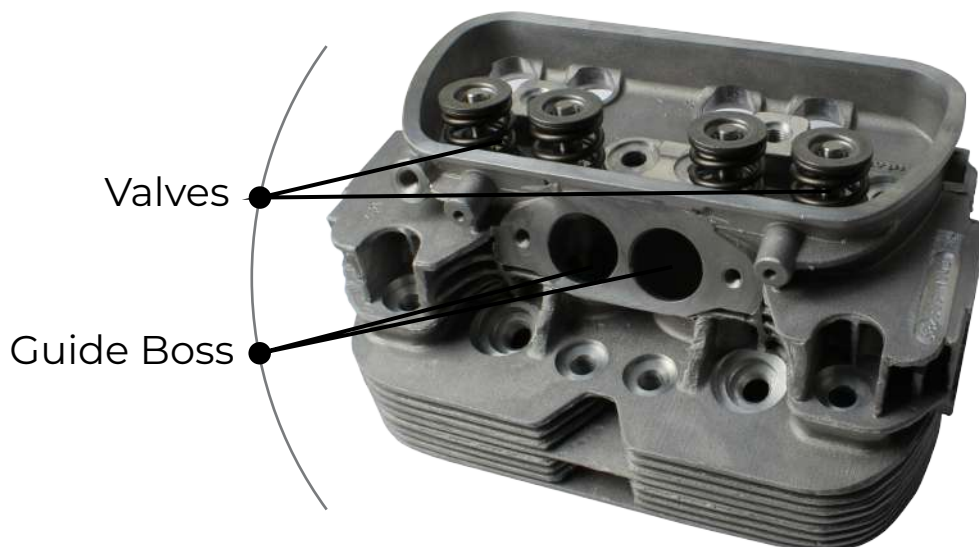
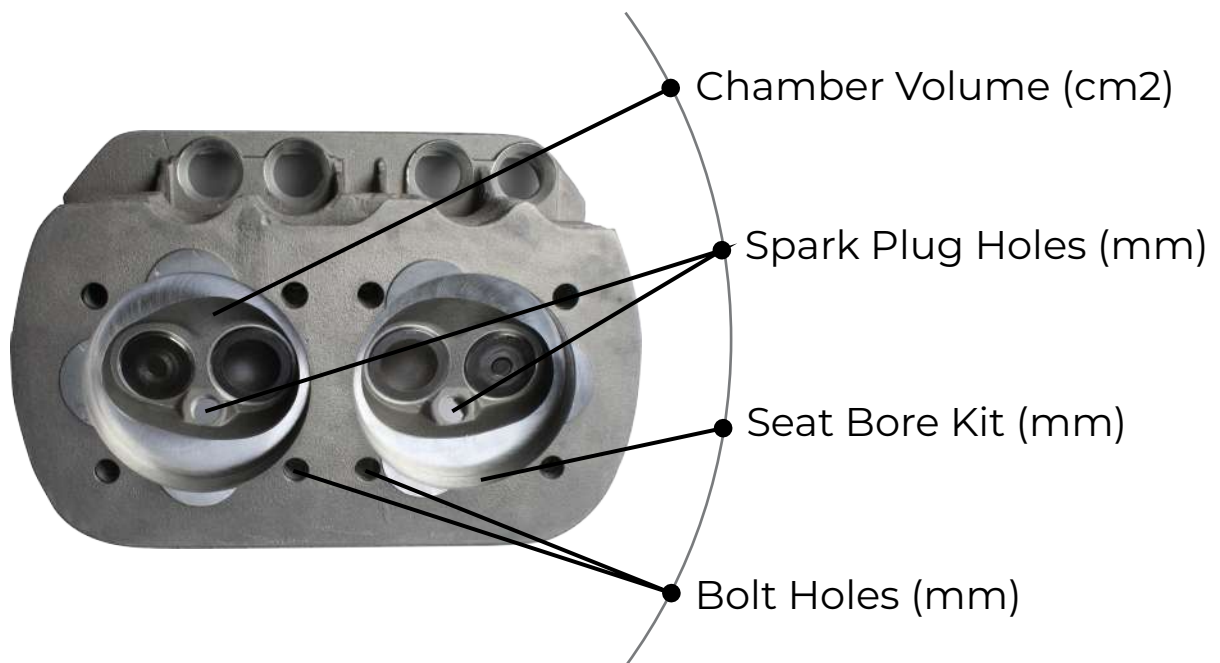



# Air Cooled Oil Pumps

Connecting Rods parameters options, according partnumbers and required performances.

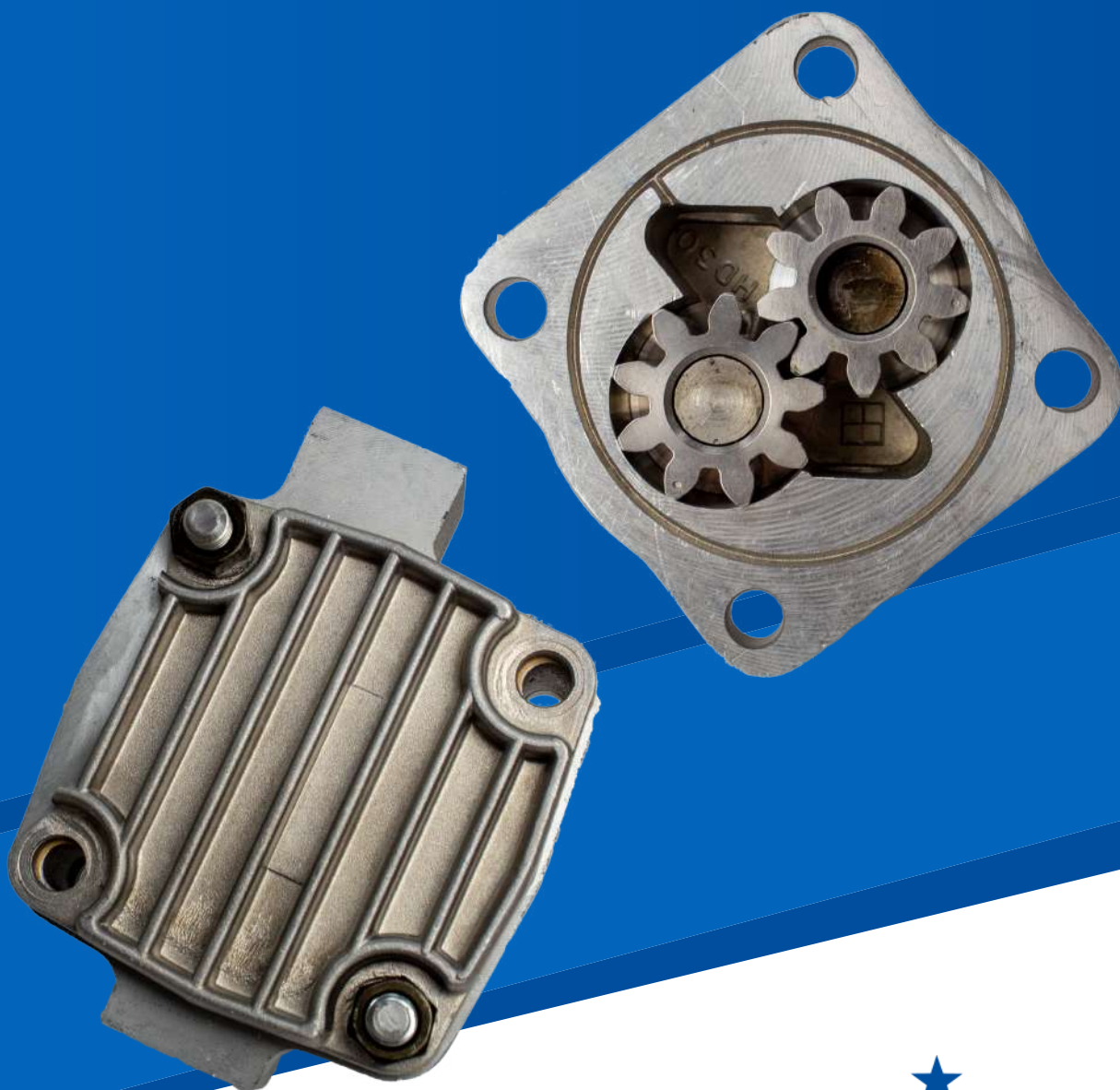

**AutoLinea**  
— performance —



# Technical Information:

## Air Cooled Oil Pump.

Engine	Autolinea Part Number	OEM	Studs	Flange	Gear
1.3L/1.5L/1.6L	103-00003	311.115.107-AK	8mm	8mm	21mm
1.5L/1.6L	103-00042	111.115.107-AK/HD	8mm	8mm	26mm
1.5L/1.6L	103-00014	111.115.107-BK	8mm	4mm	26mm
1.3L/1.6L	103-00045	111.115.107-AK SUPER/HD	8mm	12mm	30mm
1.3L/1.6L	103-00043	111.115.107-BK/HD	8mm	8mm	30mm
1.3L/1.5L/1.6L/ 1.7L/1.9L/2.1L/ 2.3L	103-00015	-	8mm	-	-
1.3L/1.5L/1.6L	103-00010	311.115.107-AK/HD	8mm	12mm	26mm

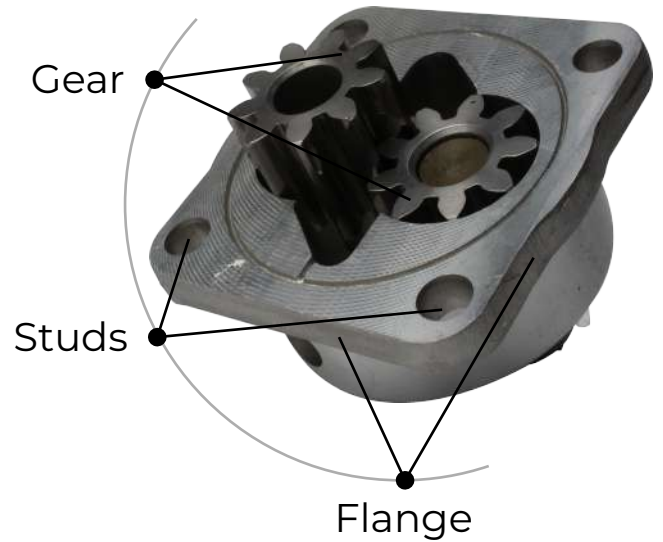

# Air Cooled Connecting Rods

---

Connecting Rods parameters options, according partnumbers and required performances.



**AutoLinea**  
— performance —

# Technical Information:

## Air Cooled Connecting Rods

Engine	Autolinea Part Number	OEM	Technical Information
1.6L	102-00025	311.105.401B 040.105.401.1	22mm pin Straight Connecting Rod

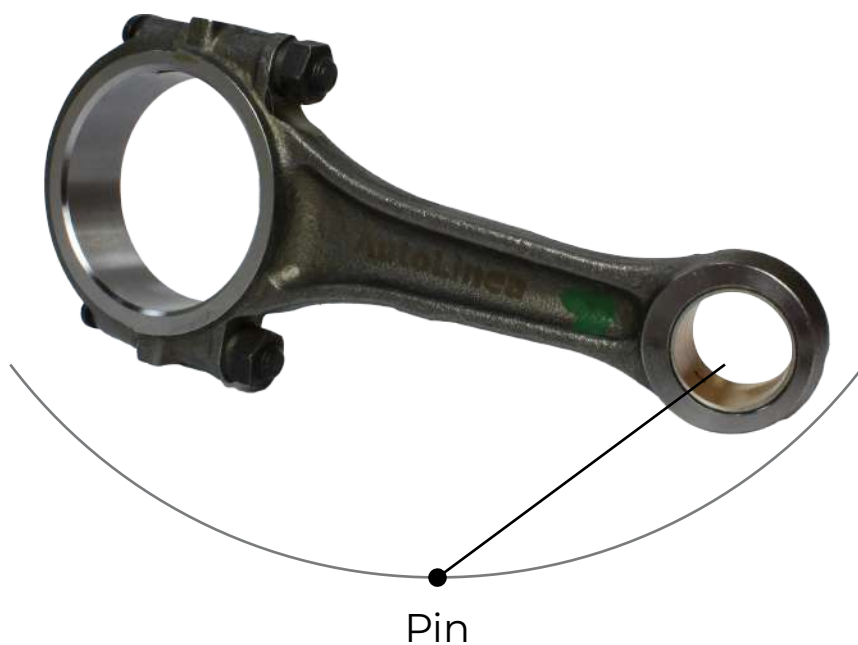



## Contact us:

+55 41 3514-5417

[export@autolinea.com.br](mailto:export@autolinea.com.br)

[autolinea.com.br](http://autolinea.com.br)

